

## TinyCOMP for the Atari 2600 Console NTSC

Version 1.4 – June 2022

It's Cute! It's positively microscopic. It's TinyCOMP: a universal RF to Composite output (North America) mod board, that allows you to convert many classic 8-bit systems to CVBS (**NTSC**) output. No more fuzzy signals, or needing some old bulky **TV**. You can even improve the quality of video capture from original hardware! Currently known and tested to work on Atari 600XL, Timex Sinclair 1000, and Atari 2600 console, however This board could be used on other computer that have a RF modulator and no composite output. You would only have to locate the audio and video inputs into the RF modulator as the rest should be the same. This is not covered in this documentation.

The Atari 2600 comes with an RF (Radio Frequency) modulator port on the back which is connected to the "Cable In" of your TV. If you are like me, and don't really want to do this but instead want to connect to a composite monitor or so converter for HDMI, then this small project is for you.

This small circuit board will allow you connect to composite and have a reversible solution, in case you want to use RF to connect to your TV.

***This document will cover the Atari 2600 six switch also known as the "Heavy 6er". This board will work in other models however you will need to verify the pin outs of the RF modulator and the audio location.***

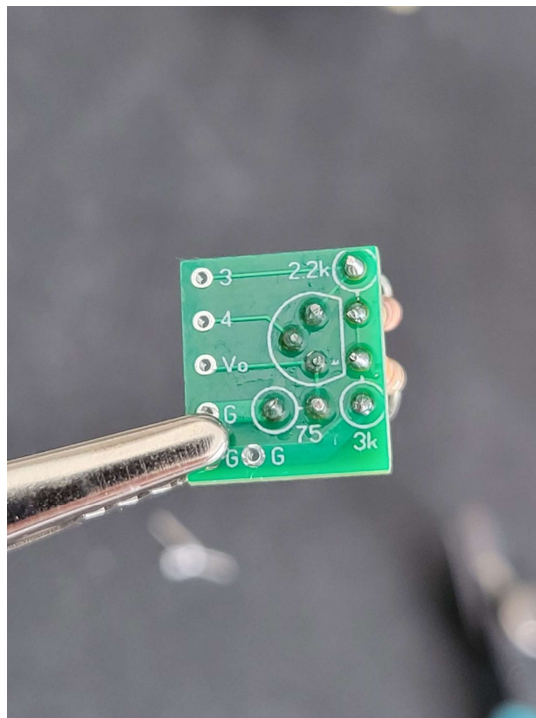

## Components

1 – 2.2K resistor

1 – 3K resistor (I used 3.3k resistor)

1 – 75-ohm resistor (I use 2 resistors 56-ohm and 18-ohm in serial to give me 74-ohms which close enough for this project)

1 – 2N2222 transistor with metal can. See schematic section below

1 – RCA female jack

Assorted colored wires for connections. Solid wire works best

Heat shrink tubing of several sizes

## Schematics

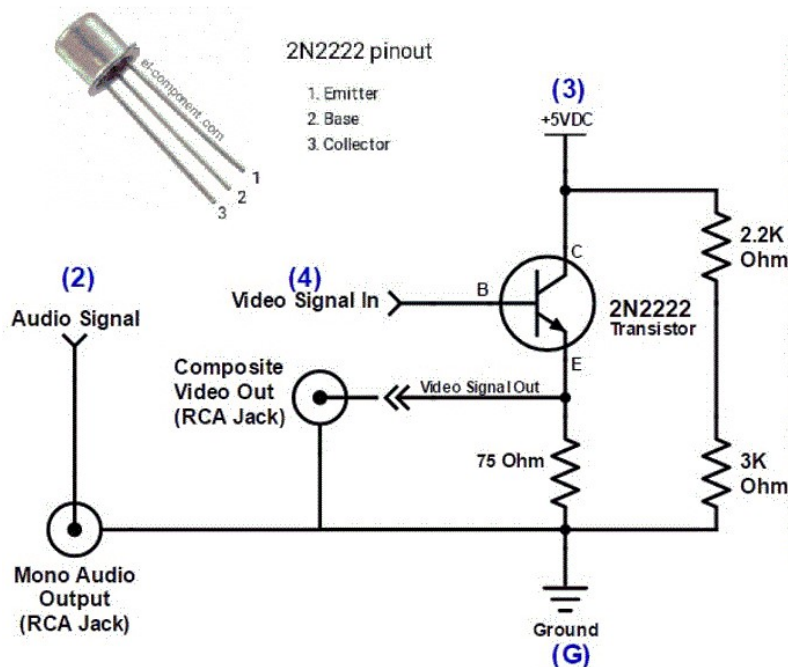

Note:

1. On the 2N2222 there is a small tab on the can of the transistor, this is the emitter connection. This is marked as "1" in the diagram on right side.
2. The schematic diagram is not mine as I found it on the internet. However, this is a simple amplifier circuit and you could use your own
3. The transistor picture was provided by el-component.com
4. *We do not take any responsibility for accuracy, damages to you, your computer, monitor etc. We have tested to the best of our abilities and will work with you correct issues. This product is sold as is and is up to the buyer to install the correct components and install correctly. Verify with manufacture's schematics before connecting any modification to*

*your computer or other equipment. If you are not sure how to connect, please contact a friend or someone who is technical and works with electronics. **Ensure your computer or console is in proper working order before you make this modification!** We do not take any responsibility for damages to your computer or console. You should be technical enough to do soldering and troubleshooting before starting this project*

### **Building and Connecting the Composite Modifications**

1. Collect all the parts needed to construct. Check **Components** section above
2. Install components of the proper side. The side with the component values should be the solder side

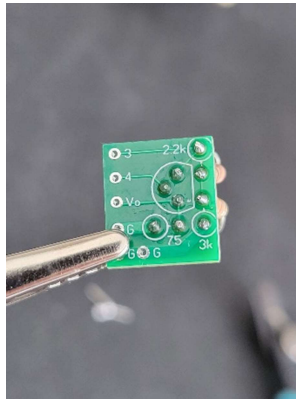

3. Install the resistor for 2.2K and 3K but first bending the leads as in the picture below. If not, there is no room to install them

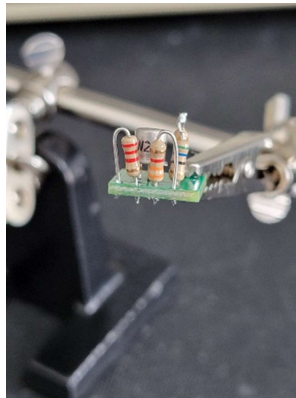

4. Install the 75-ohm resistor. If you are using 2 resistors to make this value, ensure they are soldered end to end (serial connection)

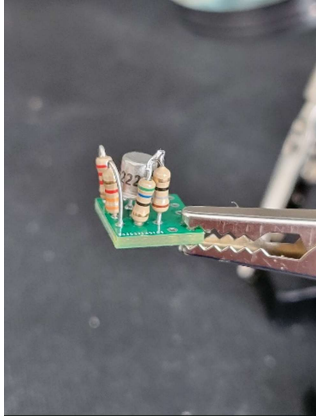

- Next, bend all resistors outwards a bit so that the transistor can be installed. Make sure that the emitter connection is placed in the hole that is marked with a small "E"

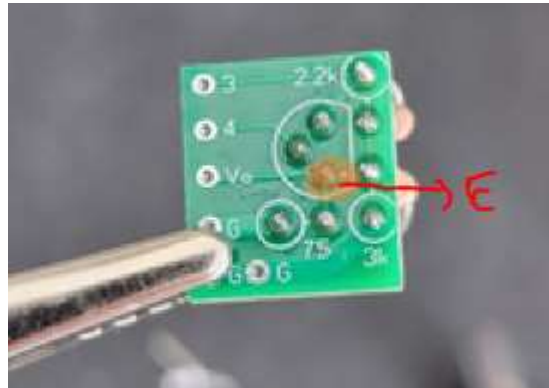

- Once installed. Cut the heat shrink tubing over each component. This will ensure the leads do not touch each other



- Install each wire as per below
  - Pin labeled "3" goes to +5V DC
  - Pin labeled "4" this is the videos input from RF modulator to the board
  - Pin labeled "G" connects to ground. There are 3 ground points, however you only need to connect to one of them and not all three
  - Pin labeled "Vo" is the composite video output. Connect this to RCA jack that is inside the RF modulator. Don't forget to cut\disconnect the resistor that connect to this RCA jack. Solder it back if you want to use the RF connection

## Video Signal

### RF Modulators with 5 pins

Pin 1 = Ground

Pin 3 = 5V DC

Pin 4 = Video signal. This is the "Video In" to the RF modification

### RF Modulators with 3 pins

Pin 1 = Ground, which is the pin further from to the modulator

Pin 2 = 5V DC, which is the middle pin

Pin 3 = Video signal, which is the remaining pin. This is the "Video In" to the RF modification board

\*\* This document will cover the RF modulator with 3 pins

Ground Connection

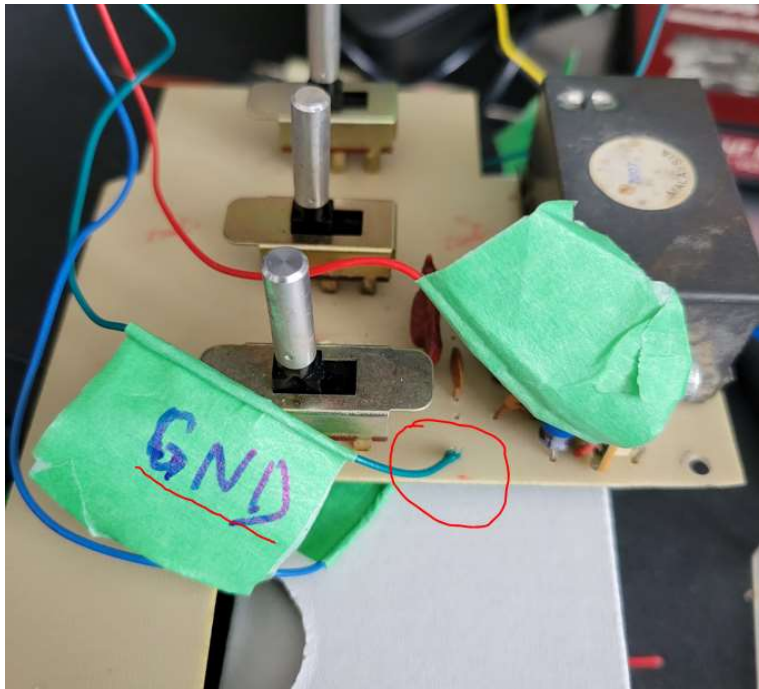

+5V Connection

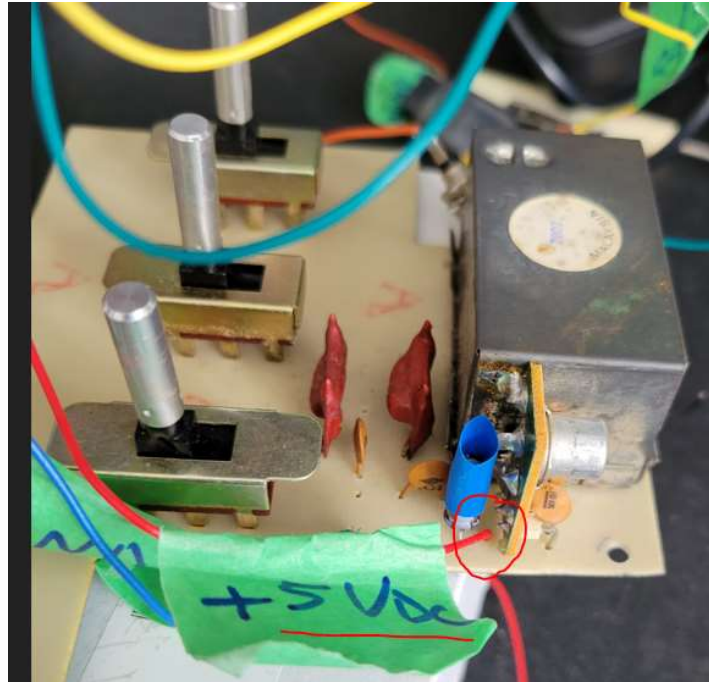

Video Input Connection

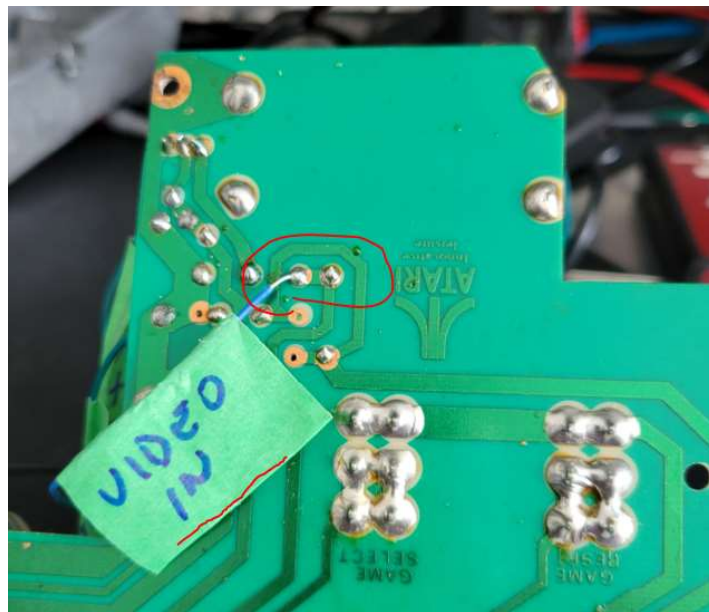

## Audio Signal

Get the audio directly from the TIA pins 12 and/or 13 or from other direct solder point (just use a tester to find the most suitable one for you). You can connect on top or bottom of PCB.



**Remove Q202 and R213 for better video result.** \*\*Only remove if need better video quality and if you do not plan to use the RF modular. If you leave these parts installed, you will get video on your composite monitor **and** your TV via the RF modulator. This was recommended by the Atari 2600 Service Manual which you can find online in many places



8. Connect the audio jack connections. Here you should drill a hole and install the RCA jack. This part is not covered here as you can find lots of YouTube videos on it. Basically, drill a whole big enough for the RCA jack connector, insert and tighten screw. Connect the ground wire (outside sleeve). Connect the center connection to connection for audio and the other for video
9. Connect the video jack connections. If you keep the RF modulator and do not remove any parts, you will need to drill another hole and install the RCA jack as you did in step above



10. Ensure all wires are connected. Double check all soldering points, wire location, etc.
11. Connect RCA cable from RF modulator or RCA jack "Video" on your composite monitor
12. Connect RCA cable from newly installed RCA jack to "Audio" on your composite monitor
13. Turn on monitor
14. Turn on your computer, wait a moment then you should see a picture

Here you can see the console running on both composite monitor (my monitor needs adjustment) and TV, via RF modulator



## **Troubleshooting**

### **No Video**

1. Check computer power supply
2. Ensure all wires are connected to the proper locations. See step 7.
3. Ensure ground connections are correct
4. Ensure +5V DC is available at Pin 3 on the RF Modulator
5. Ensure correct values are used for resistors
6. Ensure transistor is connected properly. "E" marking on the board should be where the emitter connection is made
7. Ensure is working without the modification by reconnect the resistor in the RF modulator and test that you can see a picture on a TV

### **No Sound**

1. Check computer power supply
2. Ensure all wires are connected to the proper locations. See step 7.
3. Ensure ground connections are correct
4. Ensure RCA jack is good. Using a multimeter, check that there is no connection from the RCA jack's outer connection with the middle connector

### **No Video and Sound**

1. Check computer power supply
2. Check to see if LED light on computer is on
3. Disconnect all wires added and reconnect the resistor in the RF modulator and test that you can see a picture on a TV

### **Questions\Support**

- See website for updated files
- Email: [retrointeldiy@gmail.com](mailto:retrointeldiy@gmail.com) and use tile: TinyCOMP

*We do not take any responsibility for accuracy, damages to you, your computer, monitor etc. We have tested to the best of our abilities and will work with you correct issues. This product is sold as is and is up to the buyer to install the correct components and install correctly. Verify with manufacture's schematics before connecting any modification to your computer or other equipment. If you are not sure how to connect, please contact a friend or someone who is technical and works with electronics. **Ensure your computer or console is in proper working order before you make this modification! We do not take any responsibility for damages to your computer or console. You should be technical enough to do soldering and troubleshooting before starting this project***